



SCS200 SERIES TRANSFORMERS



ALL PARTS AVAILABLE AS CLASS S OR CLASS B

MIL-STD-981

I_{PK} max (Amps)	ET (V- μ S)	Turns Ratio
5 to 20	20 to 144	1:50 to 1:100

ELECTRICAL SPECIFICATIONS

- **Operating Temperature:** -55°C to +125°C
- **Storage Temperature:** -60°C to +130°C
- **Insulation Resistance:** 10K MOhms minimum
- **Different electrical values available upon request**
- **Dielectric Withstanding Voltage:** 500 V_{AC}
- **Outgassing compliant per ASTM E595** (TML <1%, CVCM <0.1%)

MARKINGS: LASER OR INK
ALL DIMENSIONS: INCHES

THRU-HOLE PACKAGES
ALSO AVAILABLE

Package	A max.	B max.	C max.
T-2	.610	.610	.475
T-4	.610	.610	.475
G-2	.405	.405	.300

FEATURES

- **Compact**, low profile, ideal for automatic placement
- Built to meet **MIL-STD-981** specifications
- **Low Thermal Expansion, Transfer Molded Package**
- **Terminations:** Tin-lead
- Other termination finishes available upon request
- **Welded Internal Connections**
- **Moisture, Shock and Immersion Resistant**
- **Resistance to Soldering Heat:** 265°C for 10 seconds

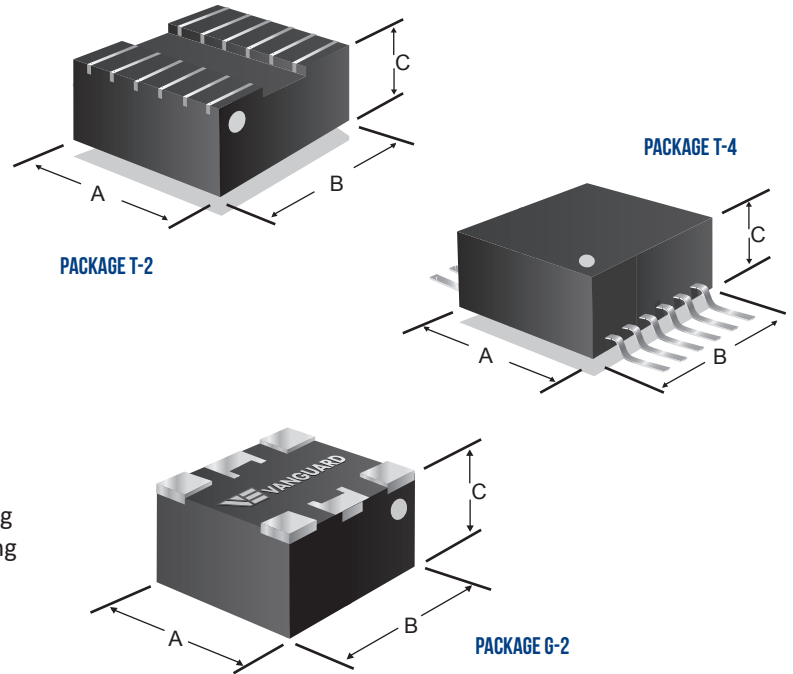

SCHEMATIC A

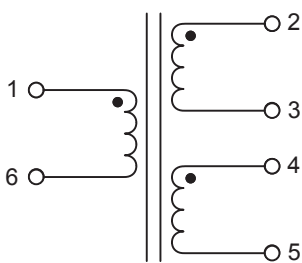

MIL-STD-981 Testing:
Add "-S" suffix for Class S Testing
Add "-B" suffix for Class B Testing

SCHEMATIC B

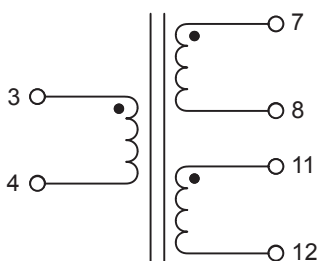

Vanguard P/N	* I_{PK} max (Amps)	ET ref (V- μ S)	DCR max (Ohms)	Inductance ref (mH)	Package	Turns Ratio	Schematic
SCS201	5	20	0.72	2.2	G-2	1:50:50	A
SCS202	10	70	1.4	5.3	T-2	1:50:50	B
SCS203	10	70	1.4	5.3	T-4	1:50:50	B
♦ SCS204	5	40	3.8	8.9	G-2	1:100:100	A
SCS205	20	144	2.9	21.0	T-2	1:100:100	B
SCS206	20	144	2.9	21.0	T-4	1:100:100	B

Inductance measured at 10 kHz, 0.1 V_{RMS} * Signal generated is a 25% duty cycle pulse wave
♦ Class "S" is available by issuing a waiver to MIL-STD-981 minimum wire size requirements

CUSTOM DESIGNS & MODIFICATIONS:

Other electrical configurations and performance characteristics are available in various sizes and package types





G-2 PACKAGE

SIDE VIEW

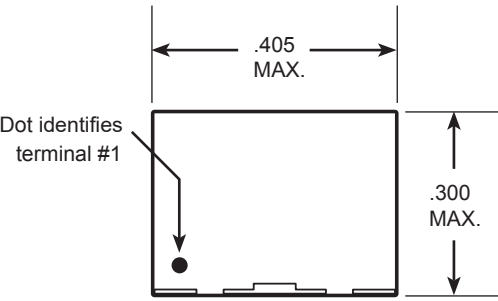

BOTTOM VIEW

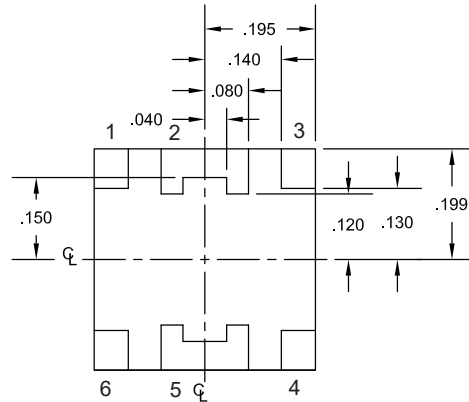

RECOMMENDED MOUNTING PAD CIRCUIT SIDE

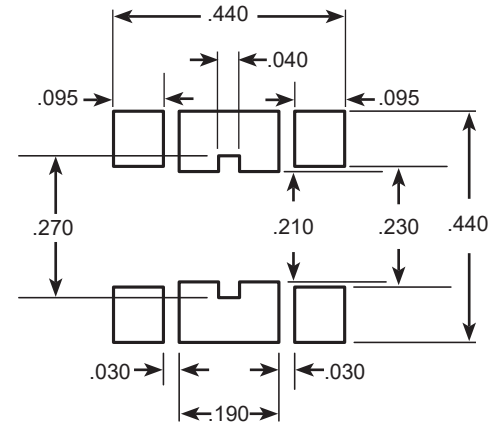

T-2 PACKAGE

TOP VIEW

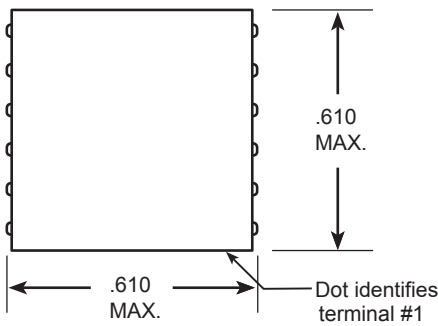

BOTTOM VIEW

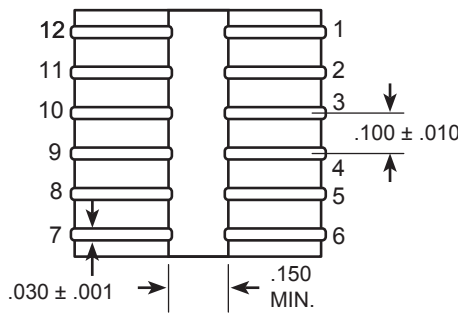

RECOMMENDED MOUNTING PAD CIRCUIT SIDE

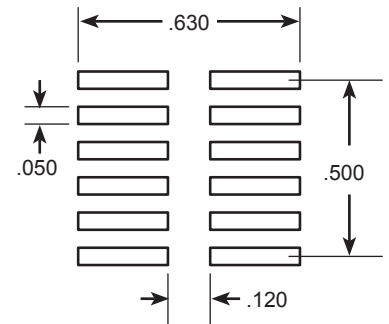

T-4 PACKAGE

TOP VIEW

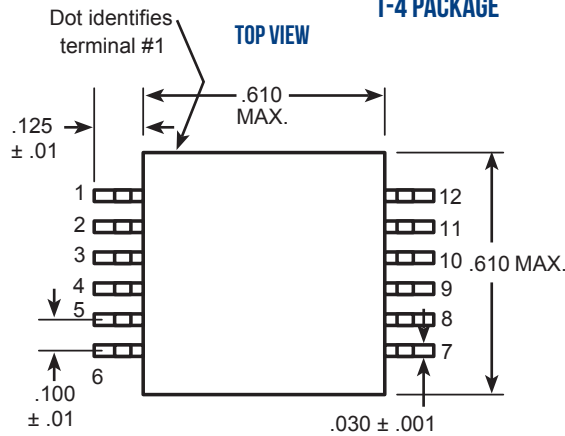

MAGNIFIED SIDE VIEW

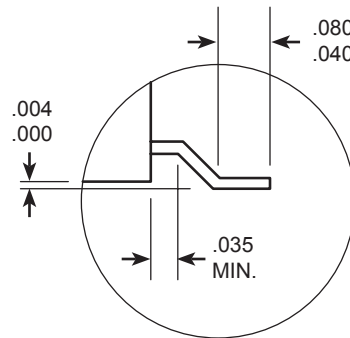

RECOMMENDED MOUNTING PAD CIRCUIT SIDE

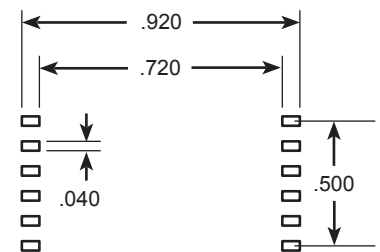

CUSTOM DESIGNS & MODIFICATIONS:

Other electrical configurations and performance characteristics are available in various sizes and package types

SCS200 SERIES

